

Raised Toilet Seat

These instructions are guidelines only. Use only as instructed by your healthcare provider.

What are Raised Toilet Seats Used For?

A raised toilet seat is used to raise the height of a toilet to a comfortable level, making it easier to sit down and get up. A toilet safety frame may be used with the raised toilet seat.

How Do I Install the Raised Toilet Seat?

Bubble-type Raised Toilet Seat (Figure 1)

- Lift the seat and lid of the toilet.
- Position the raised toilet seat with the tall end towards the rear of the toilet and the inner ring over the toilet bowl opening.
- Push down on the raised toilet seat to install in the toilet bowl.

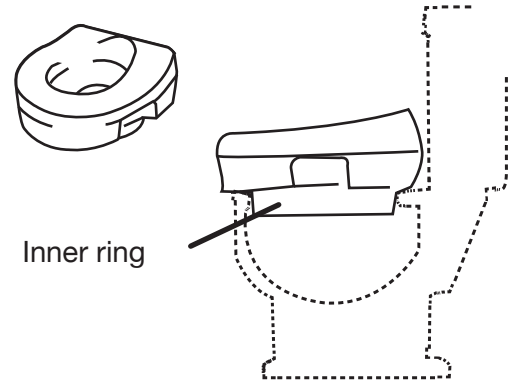

Figure 1: Bubble type raised toilet seat

Raised Toilet Seat with Adjustment Knob (Figure 2)

- Lift the seat and lid of the toilet.
- Turn the adjustment knob counterclockwise to loosen the adjustment bracket. This will allow the raised toilet seat to fit onto the toilet bowl.
- Place the raised toilet onto the bowl rim, hooking the rear flanges under the edge of the bowl. Check that the unit sits flat on bowl rim. The knob must be at the front end of toilet bowl.
- Center the raised toilet seat on the bowl rim and push it back as far as possible with your hands.
- Turn the adjustment knob clockwise to tighten. Turn until resistance is felt, then turn an additional 1/8-inch turn until secure. Turn only by hand - do not use a wrench.
- If the top rear of the seat hits the toilet seat or lid, you must remove the toilet seat for proper fit.

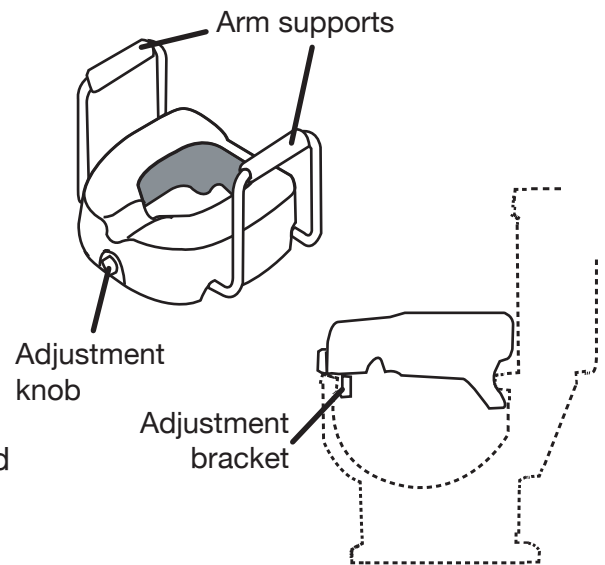

Figure 2: Raised toilet seat with adjustment knob

! **WARNING** This type of raised toilet seat is not intended for permanent installation. The unit should be loosened and retightened once a week to ensure a proper fit.

Adjustable Height Raised Toilet Seat (Figure 3)

- Lift the seat and lid of the toilet.
- Ensure that all the height adjustment clamps are at the same height.
- Lower the seat onto the bowl, ensuring the clamps slide over the bowl. If the clamps do not align properly with bowl, loosen the bolts where the clamps are attached to the seat and adjust the position of the clamps. Tighten bolts firmly after adjusting.

! **WARNING** Do not bend the metal clamps to make them fit the bowl.

- To adjust the height of the seat, loosen the nuts and bolts on each clamp and slide them up or down. Tighten the nuts and ensure that the inner part of the clamp does not pivot at all.





WARNING This type of raised toilet seat is not intended for permanent installation. The unit should be loosened and retightened once a week to ensure a proper fit.

How Do I Use the Raised Toilet Seat? (All types)



WARNING Supervision or assistance when using the raised toilet seat is recommended for users with limited physical capabilities.



WARNING Ensure that the raised toilet seat is secure.

- Back up to the raised toilet seat until you feel the back of your legs touching it.
- If present, reach back for the arm rests or hand holds.



WARNING Use the arm supports only for assistance. Do not use the arm supports to support your full body weight

- Slowly lower yourself onto the raised toilet seat by bending your elbows, hips and knees if possible.



WARNING Bubble-type seats: Be sure to center your weight on the raised toilet seat, as the seat may tip if you lean too far forward or to either side.

- To get up from the seat, push on the armrests or seat as much as comfortably possible. Make sure you have your balance before releasing your grasp from the raised toilet seat.

How Do I Care for the Raised Toilet Seat?

- Use a non-abrasive detergent or cleaner with warm water.
- Rinse well and wipe with a non-abrasive cloth.
- If the toilet seat has arm supports, frequently check that foam hand grips are secure and do not rotate.
- For raised toilet seats with a front adjustment knob, check underneath for cracks developing around the adjustor mechanism.

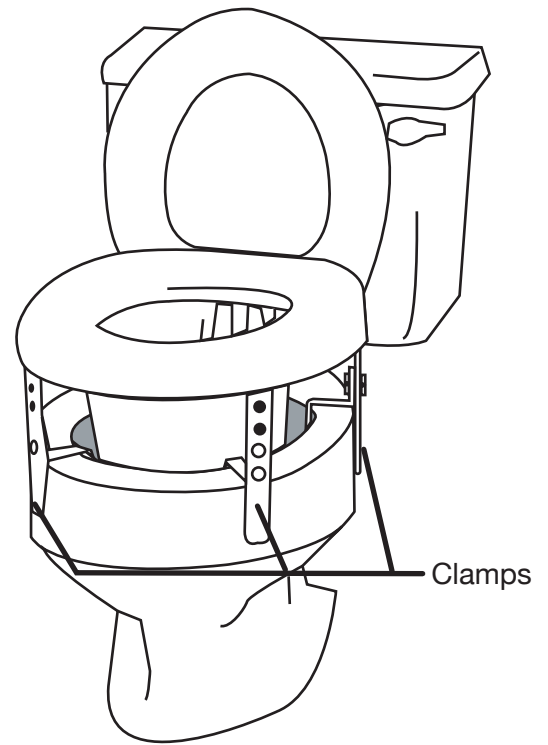

Figure 3:
Adjustable height
raised toilet seat